

CAINSTRUMENTS

33 Boulder Blvd. Stony Plain, AB, T7Z 1V6, Canada

www.cainstruments.com

Ph: (780) 963-8930

J1939 Data-Link Vehicle Databus to Analog VSS and Tach Converter

User Manual



Table of Contents

1. Installation.....	3
1.1 <i>Wiring and Wire Functions</i>	3
2. Converted Parameters.....	3
3. Troubleshooting.....	3
3.1 <i>LED Status Indicators</i>	3
3.2 <i>Checking the J1939 Databus Voltages</i>	4
4. Physical Product Dimensions.....	5
5. Electrical Specifications.....	5
6. Contact and Technical Support.....	6

Illustration Index

Illustration 1: Physical product and mounting dimensions.....	5
---	---

1. Installation

Two mounting holes on the flanges of the J1939 Data-Link are provided for mounting.

Note: The J1939 Data-Link is not waterproofed and must be mounted such that it is not exposed to the elements.

1.1 Wiring and Wire Functions

Six wires are exposed for electrical installation.

Wire Color	Function
Red	Switched 12V/24V DC
Black	GND
Purple	Tach Output (4 pulses/rev)
Orange	Speed Output (8000 ppk)
Yellow	J1939 +
Green	J1939 -

2. Converted Parameters

By default, the J1939 Data-Link supports the real-time converted of the following parameters:

SPN	Description	Output
84	Road Speed	8000 pulses/km (purple wire)
190	Engine Speed	4 pulses/revolution (orange wire)

3. Troubleshooting

3.1 LED Status Indicators

The J1939 Data-Link has 2 red diagnostic LEDs located on the PCB. The POWER LED will light solid when the device is powered. The STATUS LED will pulse quickly when the device is receiving valid J1939 data, otherwise this LED will pulse slowly or flash if there's an error.

See the chart below for a full list of error/operating modes.

LIGHTS	STATUS	ACTION
STATUS: <i>Off</i> POWER: <i>Off</i>	No power	-Check the connections to 12/24V power and GND -Check that any connected fuses are not blown
STATUS: <i>Pulsing slowly</i> POWER: <i>Solid</i>	Not receiving J1939 data	-Check the connections to the J1939 bus -Check the J1939 databus voltage -Ensure other devices on the bus are powered and working
STATUS: <i>Flashing</i> POWER: <i>Solid</i>	No J1939 databus detected	-Check connections to the J1939 databus -Check the J1939 databus voltage -Ensure other J1939 databus devices are powered and working -Ensure the J1939 databus has proper terminating resistors installed
STATUS: <i>Pulsing quickly</i> POWER: <i>Solid</i>	Everything is OK; J1939 data is being received	

3.2 *Checking the J1939 Databus Voltages*

Make sure the J1939 Data-Link is powered and the vehicle ignition is on. With a voltage meter set to DC, measure the voltages on the J1939+ and J1939- wires separately. Each wire must be measured relative to ground.

WIRE	EXPECTED VOLTAGE
J1939 +	2.5 – 3.5V
J1939 -	1.3V – 2.3V

4. Physical Product Dimensions

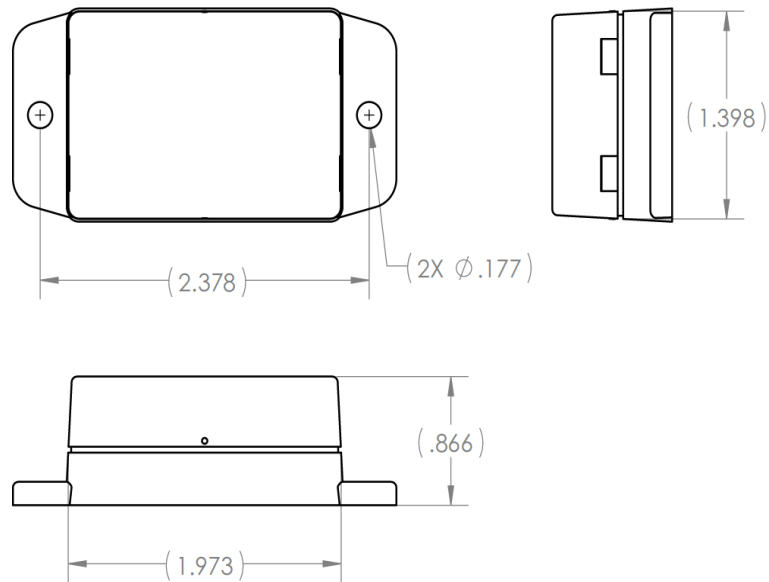

Illustration 1: Physical product and mounting dimensions

5. Electrical Specifications

Num	Rating	Min	Typical	Max	Unit
1	Operating Voltage	9.0	12.0	30.0	V
2	Transient Voltage (Max 3 positive transients, 60 seconds intervals)	-	-	80.0	V
3	Power Consumption (12VDC Supply)	-	30	45	mA
4	Operating Temperature	-40	-	80.0	°C
5	Repetitive Reverse Polarity Voltage (Voltage at GND relative to 12/24VDC)	-	-	200	V
6	Reverse Polarity Duration (GND @ +100V relative to 12/24VDC)	-	-	∞	S

6. Contact and Technical Support

Phone: +1 (780) 963-8930
Fax: +1 (780) 963-8230
Email (sales): sales@c-a-i.net
Email (support): support@c-a-i.net
Website: www.cainstruments.com
Address: Canadian Automotive Instruments Ltd.
33 Boulder Blvd.
Stony Plain, AB CANADA
T7Z 1V6